



STRONG PARTNERS. TOUGH TRUCKS.



IC Counterbalanced Lift Trucks H2.0-2.5CT

2 000 - 2 500kg

The new Hyster CT-Series of Diesel and LPG forklift trucks are available in 2,000 or 2,500kg capacities and have been designed to meet the requirements of customers who operate in low intensity or medium duty operations. By configuring this truck for specific applications only, the CT provides a new opportunity for customers to reduce the level of their investment in materials handling.

The H2.0-2.5CT retain the familiar design and solid construction, innovation and dependability Hyster is well-known for, while at the same time being carefully matched to the needs of moderate duty cycles. With right-sized components, reduced electronic complexity and a simplified list of options, Hyster has developed a cost-effective solution for medium-duty materials handling operations with lower operating hours.

Although Hyster is renowned for providing tough trucks to demanding applications, CT-Series models are designed to sustain conventional operation for short periods of time, or lighter duty work cycles for longer – typical operating hours will be in the region of 500-1,000 hours per annum.



Renowned Reliability & Performance with Low Operating Costs

In the right application, CT-Series models will still deliver renowned Hyster reliability, ensuring maximum uptime and reduced costs. Hyster has invested over 75 years' experience in selecting proven components like sealed electrical connectors, O-ring face seal fittings and a well-regarded durable powershift transmission. A simplified electrical system retains the benefits of CANbus wiring, connecting up application-matched components, which reflects Hyster's no compromise approach to quality and durability.

The CT provides target customers with the right performance characteristics – the electronically controlled Powershift transmission delivers fast load handling and smooth direction changes. Fast hydraulics and the optional integral sideshift allow loads to be optimally positioned quickly and the responsive electronically-controlled inching adjustments gives the operator better control of load positioning.

As the H2.0-2.5CT has been designed to operate efficiently in specific applications, it offers exceptional value for money. An efficient 2.6L Diesel or 2.0L LPG engine, single-speed transmission and lighter overall weight help to maximise efficiency and deliver lower fuel costs providing an ideal balance between the amount of loads moved and fuel used.

Over the lifetime of the truck, the savings continue to add up thanks to the dependability of components, delivering lower overall operating costs.



The Ideal Workplace Environment

The more comfortable operators are, the more productive they will be over the course of the shift, making the business more profitable. The operator compartment boasts a simple 3-point entry system, with easy on-off access and a low step height of 38cm. Whole Body Vibration levels are low thanks to the isolated powertrain and the standard FLM80 full-suspension seat. The driving position delivers the ideal work place environment for operators – ample foot space, and ideally positioned seat mean that all controls are within easy reach – a 30cm diameter steering wheel with spinner knob, with an adjustable steering column offers infinite adjustments and comfort. Furthermore, all round visibility is optimised throughout the handling operation.

Easy Maintenance Maximises Uptime

The “cowl-to-counterweight” service access, with 65° opening hood and one-piece removable floor plate help to reduce the amount of time the truck has to be stationary and reveal engineering advantages made to keep your truck, and your operation, running smoothly, such as sealed electrical connectors with IP66 rating against ingress of dirt and water.

As with all Hyster products, the CT is supported by a network of over 150 dealer locations across Europe, Middle East & Africa, with over 3000 trained service technicians ready to respond to your maintenance needs.



Application Guide

Attributes	H2.0CT	H2.5CT
Operation	Low intensity applications	
Typical Shifts per Day	1 shift, light 2nd shift	
Typical Hours per Year	Up to 1000	
Typical Operation Frequency	Intermittent	
Duty Cycle Levels	Moderate	
Ramp Usage	Occasional	
Fuel Type	Diesel / LPG	
Standard Engine	2.6L / 2.0L	
Engine Power	29,1kW / 30,2kW	
Mast Types	3-Stage Full Free Lift	
Attachment Compatibility	Carriage or Sideshift only	
Hydraulic Functions	1 auxiliary function, available with Sideshift only	
Travel Speeds (with load, km/h)	16,9 / 17,4	
Ast 1000 x 1200 wide (mm)	3563	3624
Lift Speed with load (m/s)	0,42 / 0,43	0,41 / 0,42
Gradeability laden @1,6 km/h	29,3% / 25,1%	26,1% / 22,5%

Application Types:

- Home Improvement Stores ■ Wholesale & Retail Outlets ■ Secondary Distribution ■ Third Party Logistics ■ Independent Retail

Standard Features:

- 2.0L Mazda LPG or 2.6L Yanmar Diesel Engine
- Powershift Single Speed Transmission
- Drum Brakes
- Hyster Stability Mechanism
- Pneumatic Shape Solid Tyres – Front: 6.5 x 10-10, Rear: 18 x 7-8
- 3-stage Full Free Lift Mast – 4350 mm Maximum Fork Height
- 5 Degree Forward / 5 Degree Back Tilt
- 977mm Class II Carriage
- 1000mm Forks
- Vinyl Full-Suspension Seat with Seatbelt
- Cowl-Mounted Levers
- Direction Lever
- 2150mm High Overhead Guard
- Rear Reflectors
- Low Diesel and LPG Warning Indicator
- Coolant Temperature warning light

Options

- **Masts:** 3-st Full Free Lift: 4800mm, 5100mm
- Load Backrest
- 3rd hydraulic function (Integral Sideshift)
- 1100, 1200mm Forks
- Semi-Suspension Vinyl Seat
- **Light Kit:** Rear brake lights, marker lights and reverse lights, halogen front and rear worklights
- Amber LED Strobe Light-low or high mounted
- Back-up Alarm
- Dual Rearview Mirrors
- Rear Drive Handle with Horn Button

Truck Dimensions

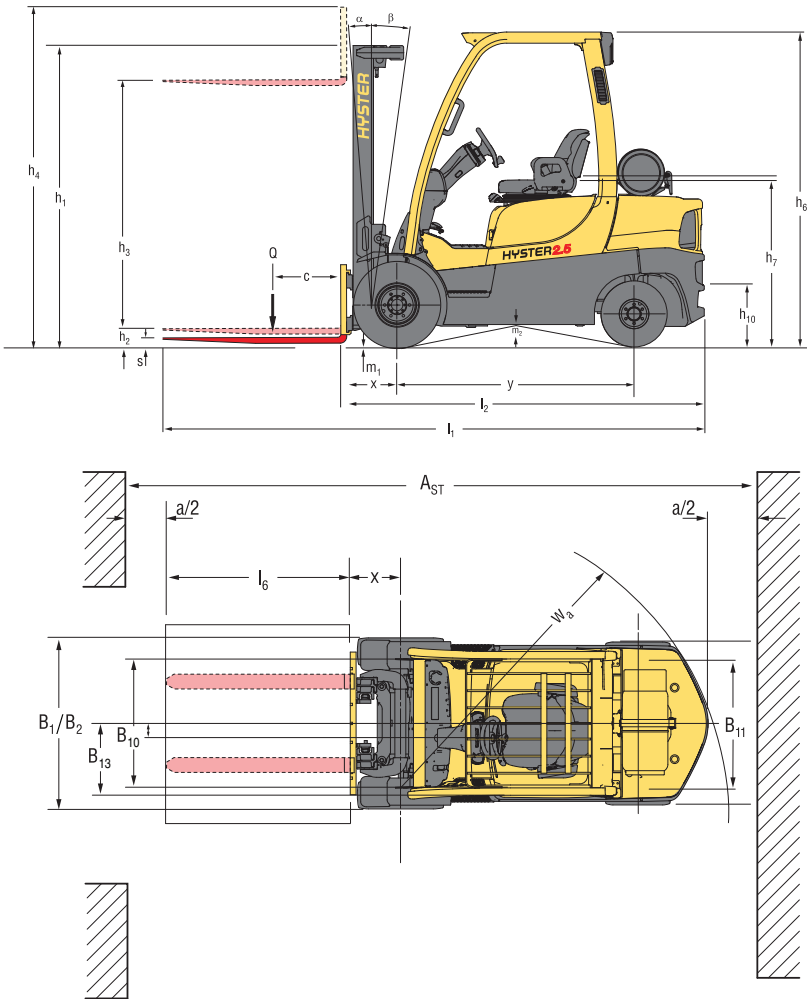

= Centre of gravity of unladen truck

$$A_{st} = W_a + x + l_g + a \text{ (see lines 4.33 \& 4.34)}$$

a = Minimum operating clearance

(V.D.I. standard = 200 mm BITA recommendation = 300 mm)

l_g = Load length

Mast and Capacity Information

Masts H2.0-2.5CT

	Maximum fork height (mm)	Backtilt	Overall lowered height (mm)	Overall extended height (mm)	Free lift (top of forks) (mm)
2 Stage DFL	3 332	5°	2 176	4 555♣	140
	3 832	5°	2 426	5 055♣	140
3 Stage FFL	4 325	5°	2 049	5 537♣	1 554♣
	4 775	5°	2 199	5 987♣	1 704♣
	5 075	5°	2 299	6 287♣	1 804♣

Capacities H2.0-2.5CT

Capacity in kg @ 500 mm load centre

Pneumatic shaped solid tyres					
	Maximum fork height (mm)	Without side shift		With integral side shift	
		H2.0CT	H2.5CT	H2.0CT	H2.5CT
2 Stage DFL	3 332	2 000	2 500	1 920	2 400
	3 832	2 000	2 500	1 910	2 400
3 Stage FFL	4 325	2 000	2 500	1 900	2 400
	4 775	1 800	1 930	1 760	1 900
	5 075	1 500	1 610	1 460	1 570

NOTES

- ♣ with load backrest
- ♠ without load backrest

To calculate truck capacities with alternative truck specifications to the ones shown in the above tables, please consult your Hyster dealer.

The rated capacities shown are for masts in a vertical position on trucks equipped with standard or sideshift carriage, and nominal length forks.

Rated Capacities

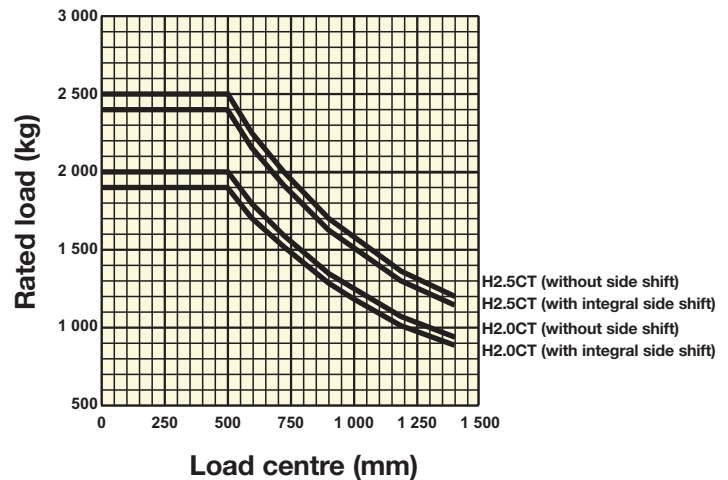

Load Centre

Distance from front of forks to centre of gravity of load

Rated Load

Based on vertical masts up to 4 325mm, top of forks

H2.0CT, H2.5CT

		HYSTER	HYSTER	HYSTER	HYSTER					
CHARACTERISTICS	1.1	Manufacturer								
	1.2	Model designation								
	1.3	Power: battery, diesel, LPG, electric mains								
	1.4	Operation: manual, pedestrian, stand, seat, orderpicker								
	1.5	Load capacity	Q (kg)							
	1.6	Load centre	c (mm)							
	1.8	Load distance	x (mm)							
	1.9	Wheelbase	y (mm)							
			H2.0CT	H2.0CT	H2.5CT	H2.5CT				
		Diesel	LPG	Diesel	LPG					
		Seat	Seat	Seat	Seat					
		2 000	2 000	2 500	2 500					
		500	500	500	500					
		388	388	388	388					
		1 623	1 623	1 623	1 623					
WEIGHT	2.1	Unladen weight								
	2.2	Axle loading with load, front/rear								
	2.3	Axle loading without load, front/rear								
		3 400	3 240	3 675	3 520					
		4 806	594	4 727	513	5 635	540	5 493	527	
		1 712	1 688	1 632	1 608	1 630	2 025	1 560	1 960	
WHEELS & TYRES	3.1	Tyres: L=pneumatic, V=solid, SE=pneumatic-shaped solid								
	3.2	Tyre size, front								
	3.3	Tyre size, rear								
	3.5	Number of wheels, front/rear (X = driven)								
	3.6	Track width, front	b _f (mm)							
	3.7	Track width, rear	b _r (mm)							
			SE	SE	SE	SE				
		6.5 x 10-10	6.5 x 10-10	6.5 x 10-10	6.5 x 10-10					
		18 x 7-8	18 x 7-8	18 x 7-8	18 x 7-8					
		2X	2	2X	2	2X	2	2X	2	
		978	978	978	978					
		895	895	895	895					
DIMENSIONS	4.1	Mast tilt, forward α /back β								
	4.2	Height of mast, lowered								
	4.3	Free lift \blacksquare								
	4.4	Lift height \blacksquare								
	4.5	Height of mast, extended \square								
	4.7	Height to top of overhead guard \circ								
	4.8	Seat height \bullet								
	4.12	Towing coupling height								
	4.19	Overall length								
	4.20	Length to face of forks								
	4.21	Overall width								
	4.22	Fork dimensions								
	4.23	Fork carriage to DIN 15173. Class, A/B								
	4.24	Fork carriage width \blacktriangledown								
	4.31	Ground clearance under mast, with load								
	4.32	Ground clearance at centre of wheelbase								
	4.33	Aisle width with pallets 1 000mm long x 1 200mm wide \triangle								
	4.34	Aisle width with pallets 800mm wide x 1 200mm long \triangle								
	4.35	Outer turning radius								
	4.36	Inner turning radius								
		5	5	5	5	5	5	5	5	
		2 049	2 049	2 049	2 049					
		1 554	1 554	1 554	1 554					
		4 325	4 325	4 325	4 325					
		4 820	4 820	4 820	4 820					
		2 149	2 149	2 149	2 149					
		1044	1044	1 044	1044					
		330	330	330	330					
		3 426	3 426	3 491	3 491					
		2 426	2 426	2 491	2 491					
		1 147	1 147	1 147	1 147					
		40 x 100 x 1 000	40 x 100 x 1 000	40 x 100 x 1 000	40 x 100 x 1 000					
		IIA	IIA	IIA	IIA					
		977	977	977	977					
		98	98	98	98					
		127	127	127	127					
		3 763	3 763	3 824	3 824					
		3 963	3 963	4 024	4 024					
		2 175	2 175	2 236	2 236					
		103	103	103	103					
PERFORMANCE	5.1	Travel speed with/without load								
	5.2	Lifting speed with/without load								
	5.3	Lowering speed with/without load								
	5.5	Drawbar pull with/without load @ 1.6km/h								
	5.6	Maximum drawbar pull with/without load								
	5.7	Gradeability with/without load @ 4.8km/h \dagger								
	5.8	Maximum gradeability with/without load @1.6km/h \dagger								
	5.10	Service brake								
			16.9	17.0	17.4	18.0	16.9	17.0	17.4	18.0
			0.42	0.52	0.43	0.50	0.41	0.52	0.42	0.50
		0.50	0.43	0.49	0.42	0.50	0.43	0.49	0.42	
		14.2	8.8	12.3	8.8	14.0	9.5	12.2	9.5	
		16.6	8.8	14.7	8.8	16.4	9.5	14.6	9.5	
		20.1	27.3	16.7	27.3	15.0	27.3	15.0	27.3	
		29.3	27.3	25.1	27.3	26.1	27.3	22.5	27.3	
		Hydraulic	Hydraulic	Hydraulic	Hydraulic					
ENGINE	7.1	Engine manufacturer/type								
	7.2	Engine output, in accordance with ISO 1 585 / DIN 6271								
	7.3	Governed speed								
	7.4	Number of cylinders/displacement								
	7.5	Fuel consumption in accordance with VDI cycle								
		Yanmar	Mazda	Yanmar	Mazda					
		29.1	30.2	29.1	30.2					
		2 400	2 400	2 400	2 400					
		4	2 659	4	1 998	4	2 659	4	1 998	
		2.9	2.7	3.3	2.9					
OTHER	8.1	Drive control								
	8.2	Working pressure for attachments								
	8.3	Oil flow for attachments								
	8.4	Average noise level at operator's ear \blacklozenge								
		Guaranteed sound power 2001/14/EC								
	8.5	Towing coupling type / DIN type								
		Automatic	Automatic	Automatic	Automatic					
		N/A	N/A	N/A	N/A					
		N/A	N/A	N/A	N/A					
		79	79	79	79					
		102	102	102	102					
		Pin	Pin	Pin	Pin					

Specification Data is based on VDI 2198

Equipment and weight: Weights (line 2.1) are based on the following specifications: Complete truck with 4325mm (TOF) 3-stage full free lift mast, standard carriage and 1000mm forks, manual levers and standard pneumatic shaped solid drive and steer tyres.

NOTE:

Specifications are affected by the condition of the vehicle and how it is equipped, as well as the nature and condition of the operating area. If these specifications are critical, the proposed application should be discussed with your dealer.

- Top of forks
- Without Load Backrest
- Full suspension seat in depressed position
- h₆ subject to +/- 5 mm tolerance

- ▼ add 32mm with load backrest
- △ Stacking aisle width are based on the V.D.I. standard calculation as shown on illustration. The British Industrial Truck Association recommends the addition of 100 mm to the total clearance (dimension a) for extra operating margin at the rear of the truck.
- † Gradeability figures are provided for comparison of tractive performance, but are not intended to endorse the operation of the

vehicle on the stated inclines. Follow instructions in the operating manual regarding operation on inclines.

- ◆ Measured according to the test cycles and based on the weighting values contained in EN12053

Hyster products are subject to change without notice. Lift trucks illustrated may feature optional equipment.

Notice Care must be exercised when handling elevated loads. When the carriage and/or load is elevated, truck stability is reduced. It is important that mast tilt in either direction be kept to a minimum when loads are elevated. Operators must be trained and adhere to the instructions contained in the Operating Manual.



This truck conforms to the current EU requirements.



Strong Partners, Tough Trucks, for Demanding Operations, Everywhere.

Hyster supplies a complete range of warehouse equipment, IC and electric counterbalanced trucks, container handlers and ReachStackers.

Hyster is committed to being much more than a lift truck supplier. Our aim is to offer a complete partnership capable of responding to the full spectrum of material handling issues:

Whether you need professional consultancy on your fleet management, fully qualified service support, or reliable parts supply, you can depend on Hyster.

Our network of highly trained dealers provides expert, responsive local support. They can offer cost-effective finance packages and introduce effectively managed maintenance programmes to ensure that you get the best possible value. Our business is dealing with your material handling needs so you can focus on the success of your business today and in the future.



Hyster Europe

Flagship House, Reading Road North, Fleet, Hants GU51 4WD, England.

Tel: +44 (0) 1252 810261



www.hyster.eu



infoeurope@hyster.com



[/HysterEurope](https://www.facebook.com/HysterEurope)



[@HysterEurope](https://twitter.com/HysterEurope)



[/HysterEurope](https://www.youtube.com/HysterEurope)



FORTENS, HYSTER, and  are registered trademarks in the European Union and certain other jurisdictions.

MONOTROL and YARDMASTER are registered trademarks, and DURAMATCH is a trademark in the United States and in certain other jurisdictions.

Hyster products are subject to change without notice. Lift trucks illustrated may feature optional equipment.